

## Projektübersicht

Projektname: 2019-12-08 Laborübung

Projektnummer: C0101-DC884VV14

Projektbeschreibung: Unterbau Laborübung

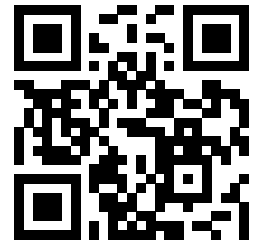

[i24.ws?C0101-DC884VV14](https://i24.ws?C0101-DC884VV14)

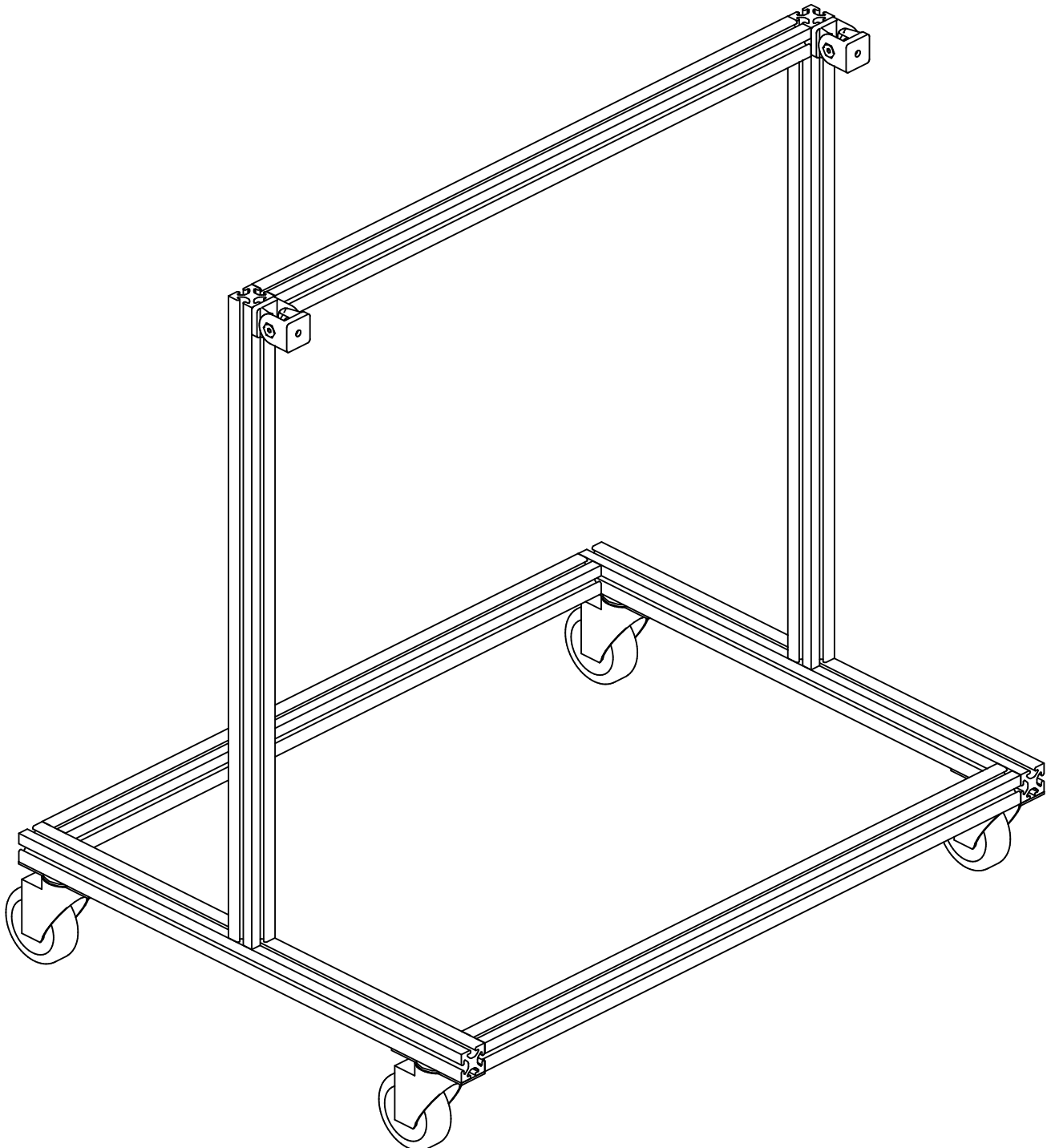

## Baugruppenübersicht

Projektübersicht .....	1
Baugruppenübersicht .....	2
Stückliste .....	3
Profilbearbeitungen .....	4

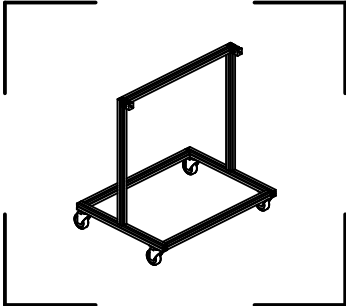

### **Baugruppe 1**

Isometrische Ansicht .....	11
Dreitafelprojektion .....	12
Explosionsdarstellung .....	13
Montageanleitung .....	14

## Stückliste

Position	Artikelbezeichnung	Artikel-Nr.	Seite	Anzahl
1	Profil 8 40x40 leicht, natur, Länge: 760mm	0.0.026.33	-	2
2v	Profil 8 40x40 leicht, natur, Länge: 900mm	0.0.026.33	5	2
3v	Profil 8 40x40 leicht, natur, Länge: 920mm	0.0.026.33	8	3
4	Befestigungssatz 8 für Lenk-/Bockrolle 140x110	0.0.670.18	-	4
5	Lenkrolle D100 120x40	0.0.633.43	-	4
6	Gelenk 8 40x40	0.0.265.31	-	2
7	Halbrundschraube M8x16, verzinkt	8.0.000.19	-	10
8	Nutenstein 8 St M8, verzinkt	0.0.026.18	-	10
9	Universal-Verbindungssatz 8, verzinkt	0.0.026.92	-	16

### Verbindungstechnik (gesamt)

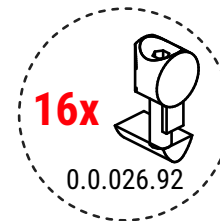
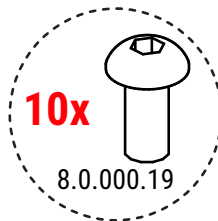
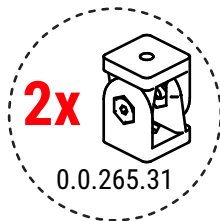

## Unbearbeitete Profile

**2x**

Teil 1, Profil 8 40x40 leicht, natur  
Artikel-Nr.: 0.0.026.33  
Länge: 760mm, Unbearbeitet

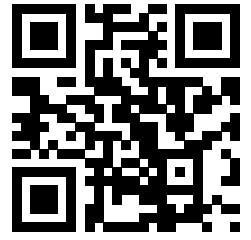
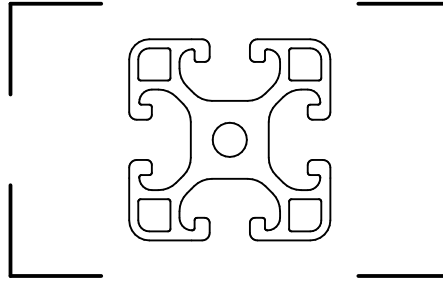

[i24.ws?C0101-DC884VV14.1](https://i24.ws?C0101-DC884VV14.1)

**2x**

Bearbeitungen Teil 2v, Profil 8 40x40 leicht, natur  
 Artikel-Nr.: 0.0.026.33, Länge: 900mm

Sicht auf Stirnseite 1

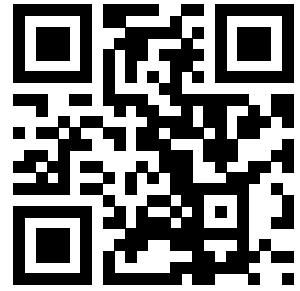
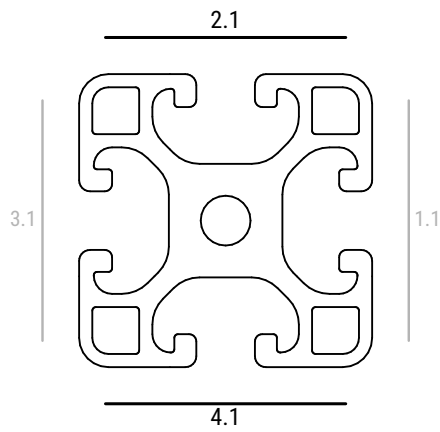

[i24.ws?C0101-DC884VV14.2v](https://i24.ws?C0101-DC884VV14.2v)

Bearbeitungstyp	Seite	Nummer	Maß (Stirnseite 1)	Bearbeitungsbezeichnung	Maß (Stirnseite 2)
D20 Stufe, D7 Bohrung	2.1	v1	880	D20x16, D7x33	20
	4.1	v2	880	D20x16, D7x33	20

Seite 2.1  
Stirnseite 1

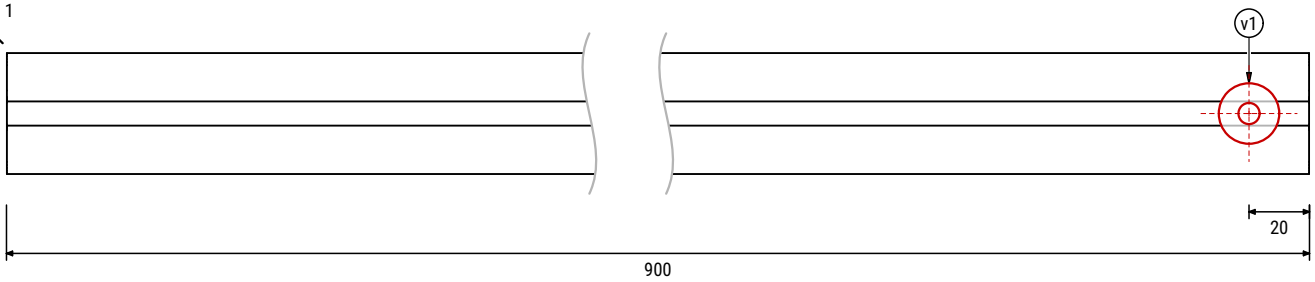

Seite 2.1

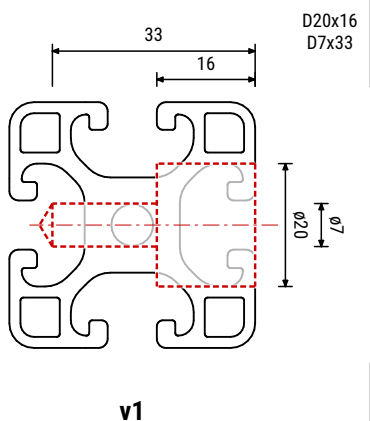

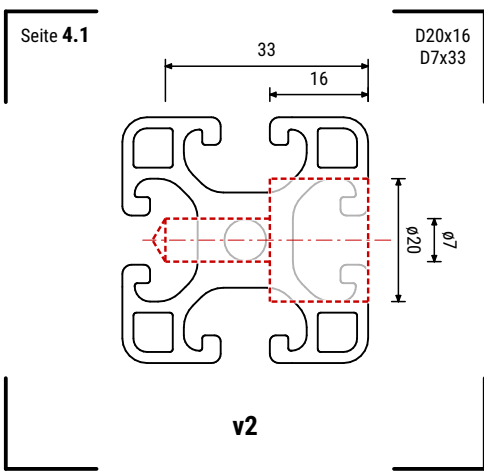
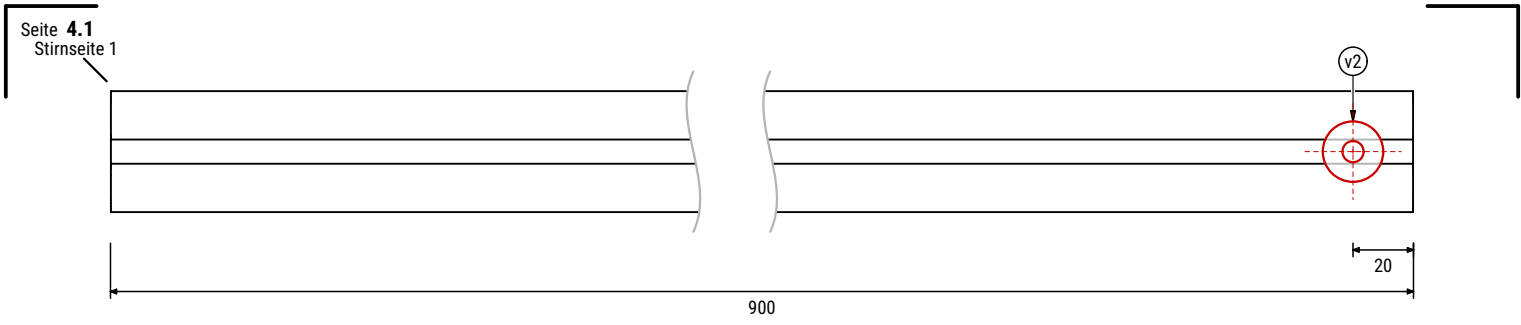

### Kontrollansicht (Bearbeitungen) Teil 2v

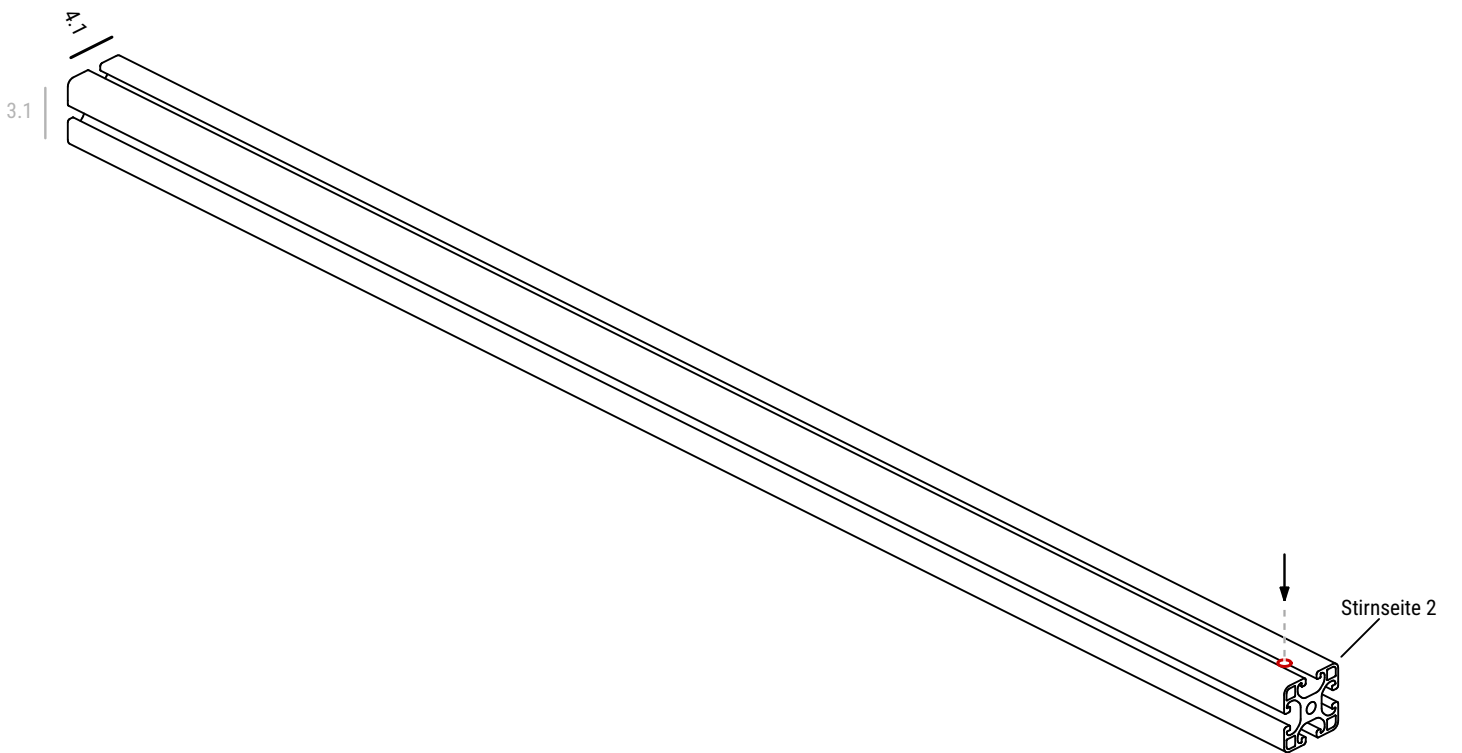
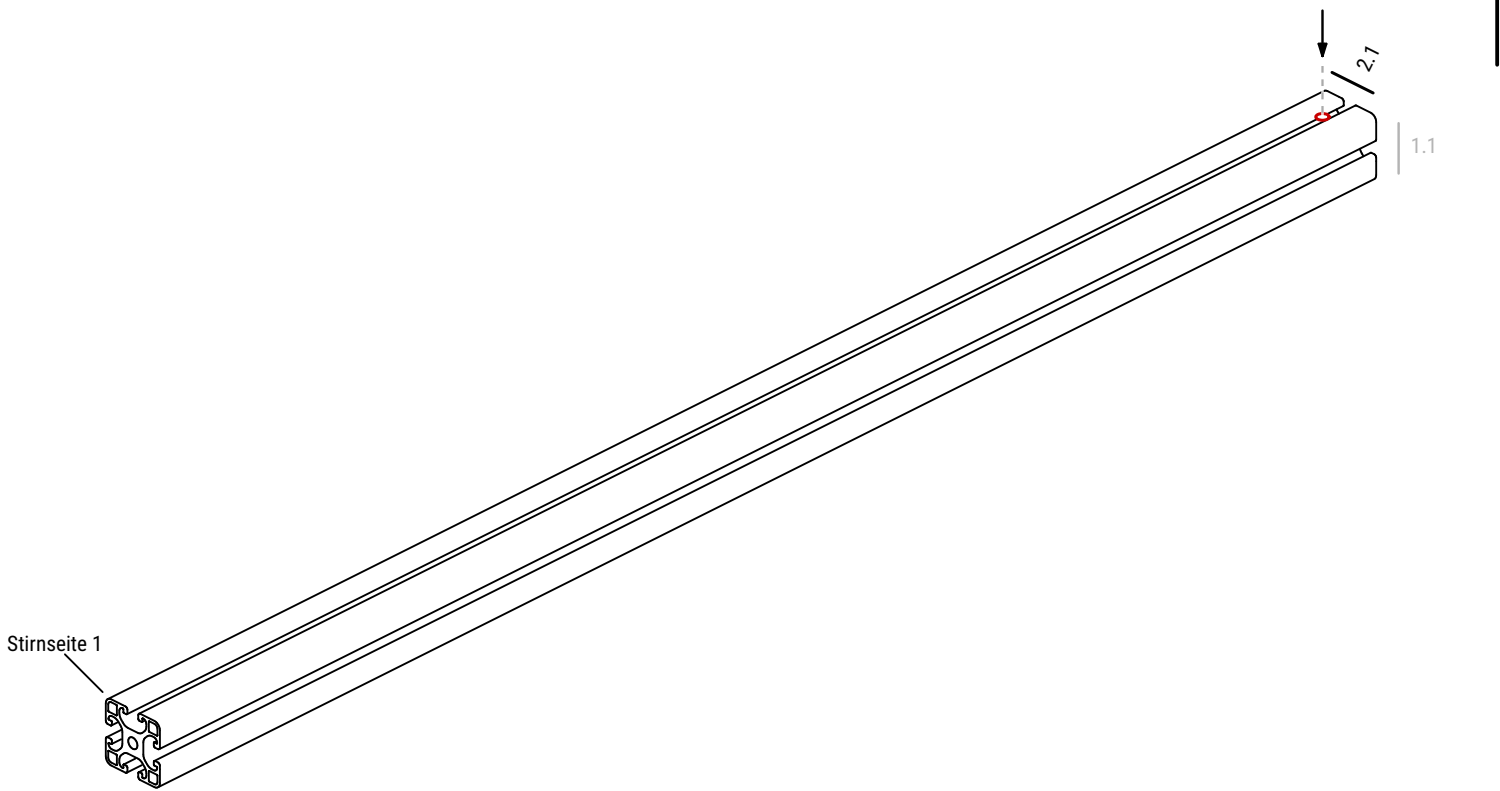

**3x**

Bearbeitungen Teil 3v, Profil 8 40x40 leicht, natur  
 Artikel-Nr.: 0.0.026.33, Länge: 920mm

Sicht auf Stirnseite 1

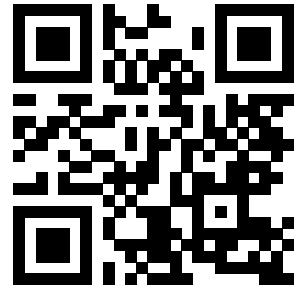
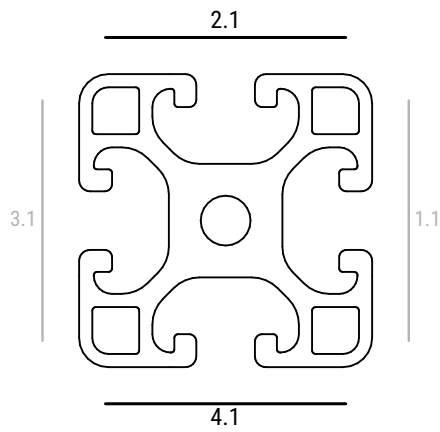

[i24.ws?C0101-DC884VV14.3v](https://i24.ws?C0101-DC884VV14.3v)

Bearbeitungstyp	Seite	Nummer	Maß (Stirnseite 1)	Bearbeitungsbezeichnung	Maß (Stirnseite 2)
D20 Stufe, D7 Bohrung	2.1	v1	900	D20x16, D7x33	20
		v2	20	D20x16, D7x33	900
	4.1	v3	900	D20x16, D7x33	20
		v4	20	D20x16, D7x33	900

Seite 2.1  
Stirnseite 1

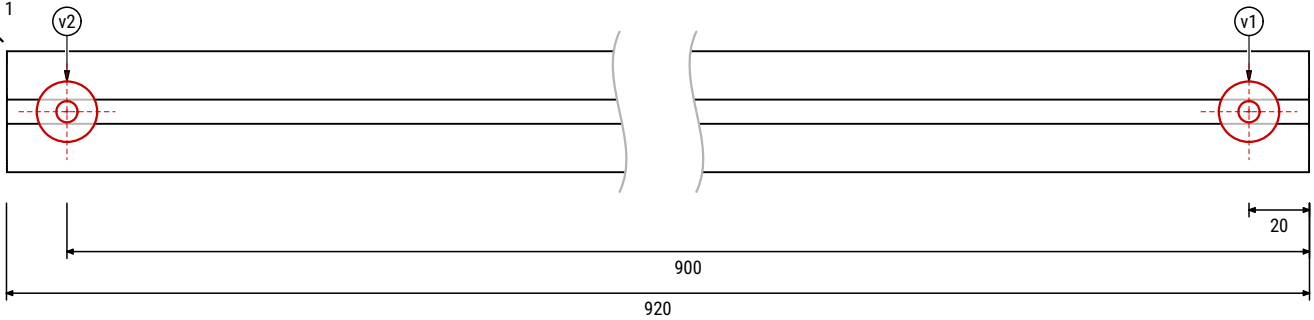

Seite 2.1

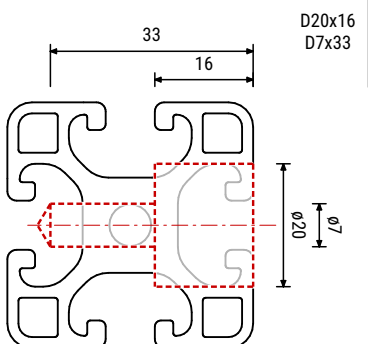

v1 v2



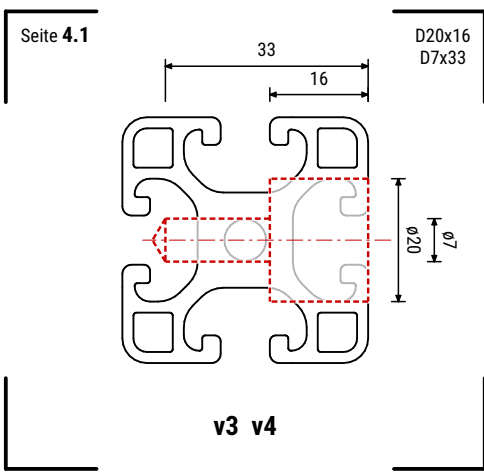
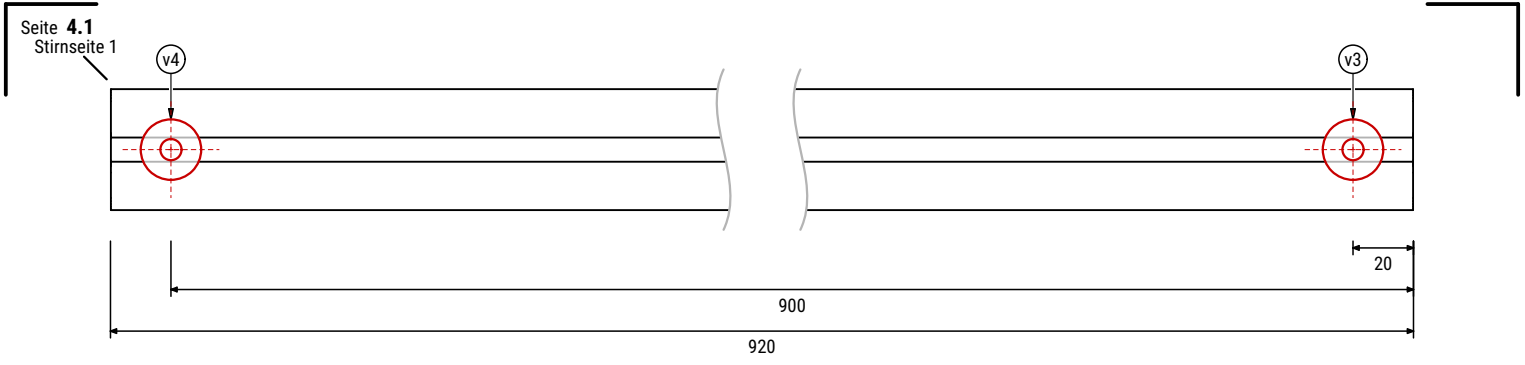

### Kontrollansicht (Bearbeitungen) Teil 3v

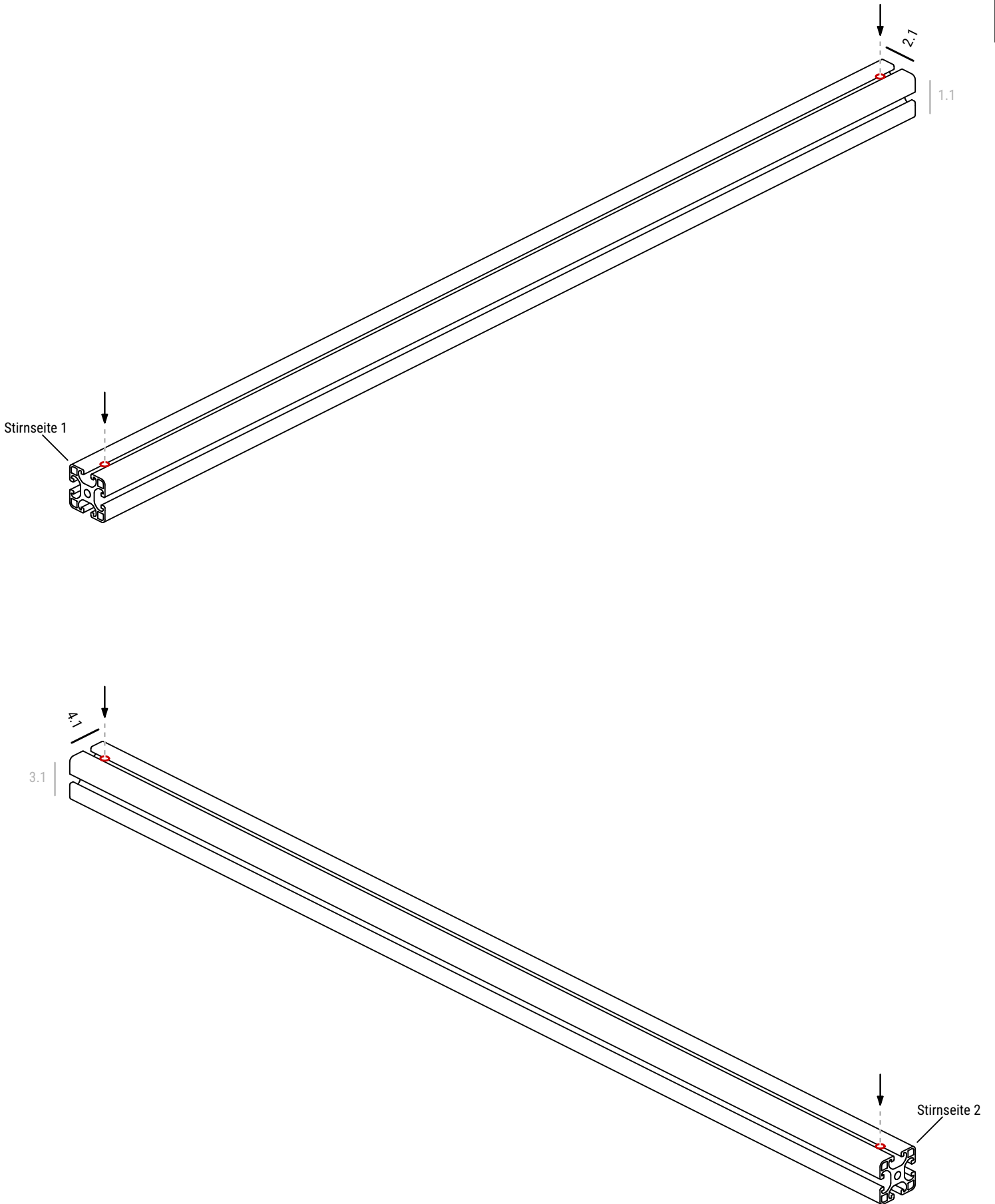

Isometrische Ansicht

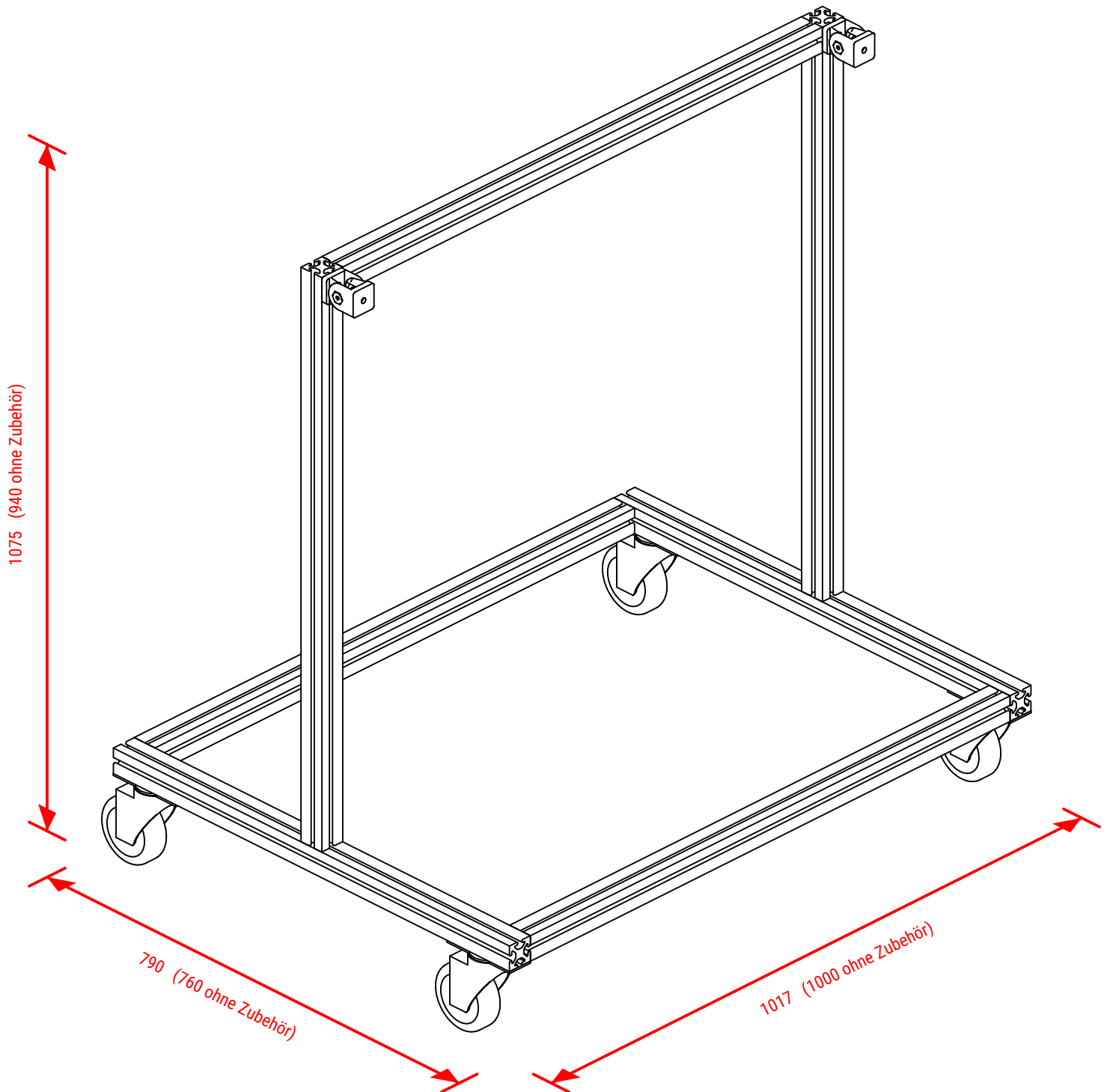

Dreitafelprojektion

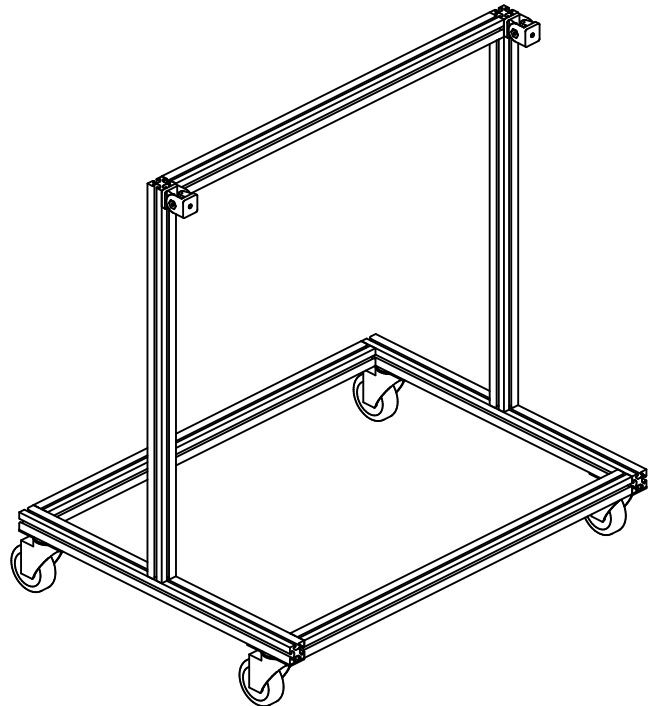
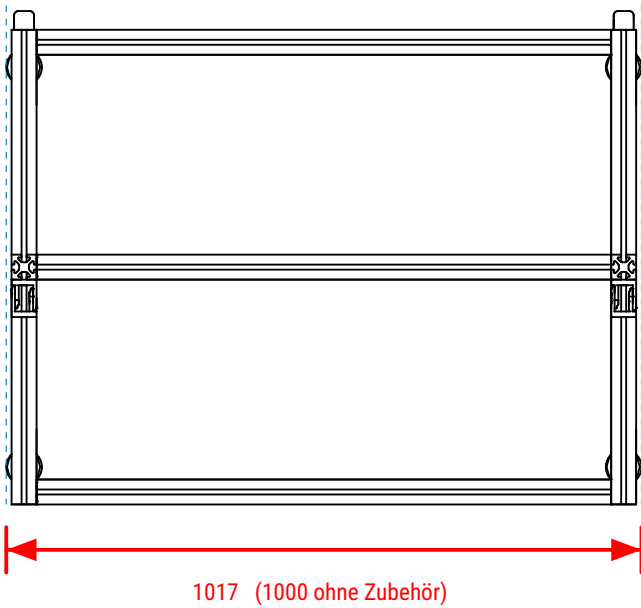
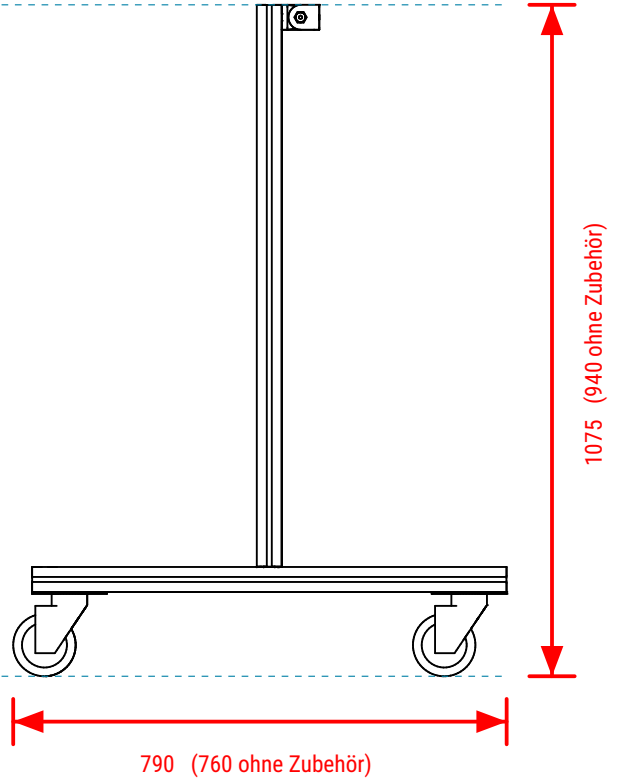
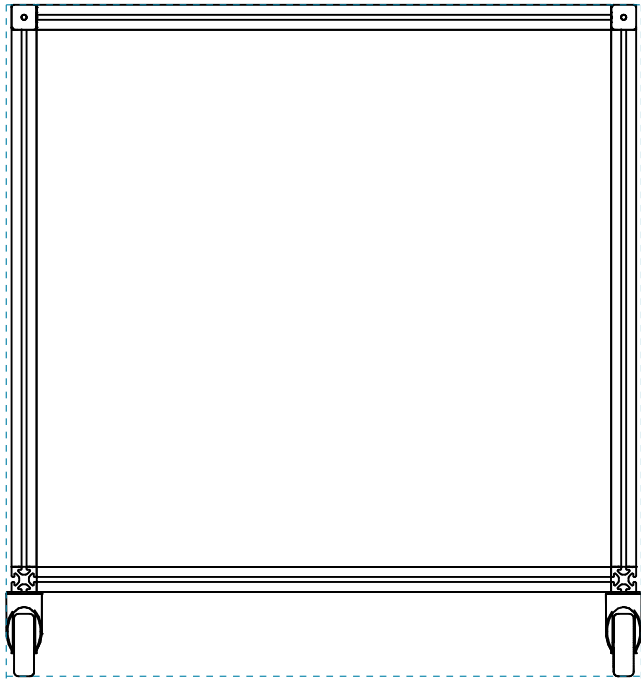

# Explosionsdarstellung

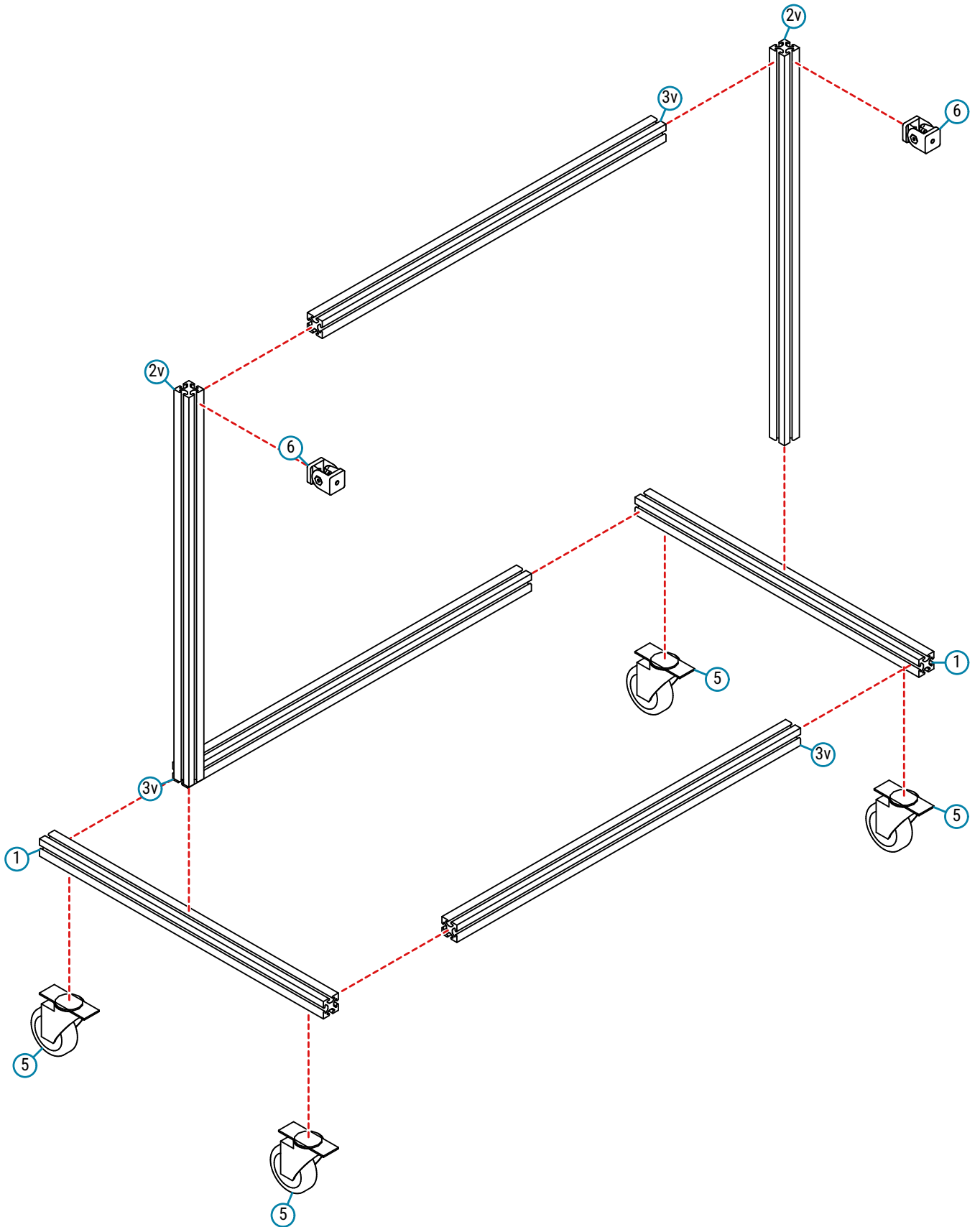

Montageanleitung

Schritt 1/ 4

Starte mit Teil 4 und 3v

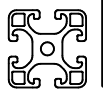

Schritt 2/ 4

Montiere 2 x Teil 2v

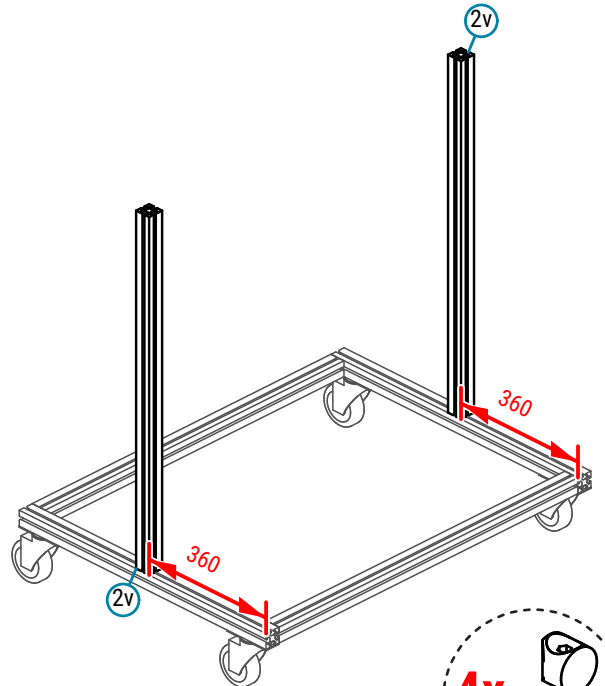
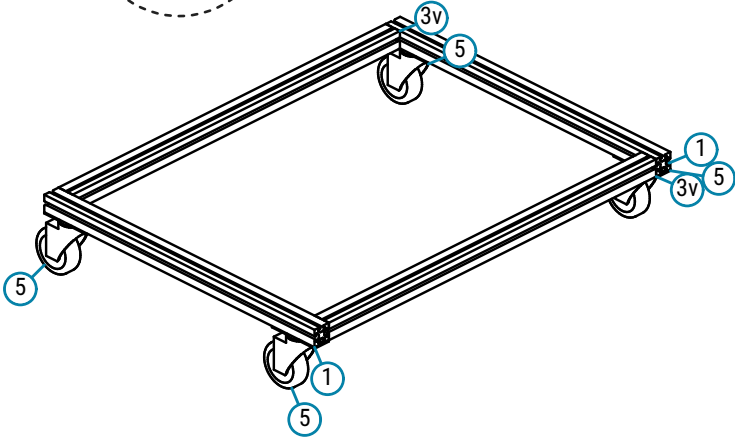
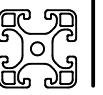

Schritt 3/ 4

Montiere 1 x Teil 3v



Schritt 4/ 4

Montiere 2 x Teil 6

